



Korea Transportation Safety Authority
Korea Automobile Testing & Research Institute

The 14th Public and Private Joint Forum in Asian Region
The 28th ASIA GOVERNMENT/ INDUSTRY MEETING

Activities of Korea in WP.29



UN Regulation No. 43 (Safety glazing)

- Proposal for Supplement 11 to the 01 Series of Amendments to UN Regulation No. 43
- To allow an additional opaque obscuration area on the Zone I
- For the optimized installation of interior rear-view mirrors or various safety and convenience features
- e.g. Lane Departure Warning System and Autonomous Vehicle Sensors
- The amendment to UN GTR No.6 has already been adopted at the 119th session of GRSG

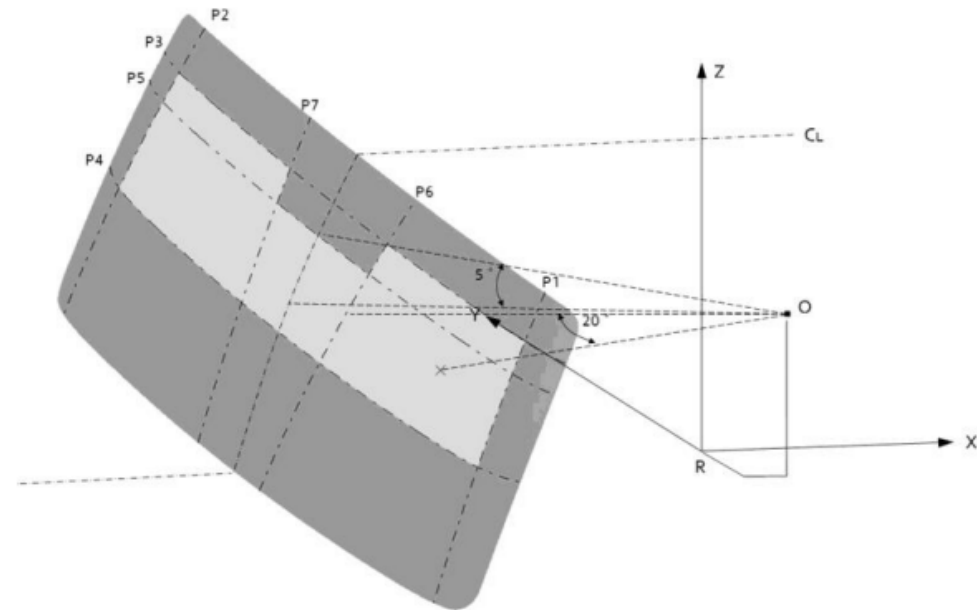
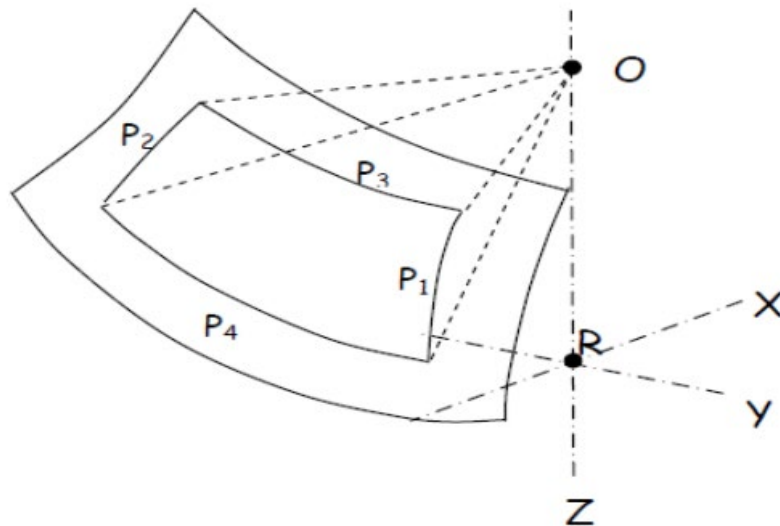

UN Regulation No. 46 (Devices for indirect vision)

- Interpretation difference
- Question on 125th GRSG,
- 6.3.2.1.1. ... The end of the pendulum comprises a hammer formed by a rigid sphere with a diameter of 165 ± 1 mm having a 5mm thick rubber covering of Shore A hardness 50.
- Adapted on 126th GRSG ,
- The end of the pendulum comprises a hammer formed by a rigid sphere with a diameter of 165 ± 1 mm and having a $5 \pm$ mm thick rubber covering of Shore A hardness 50.

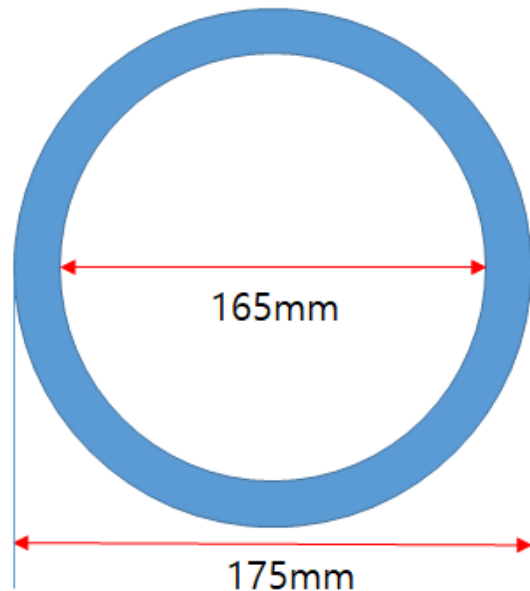

or

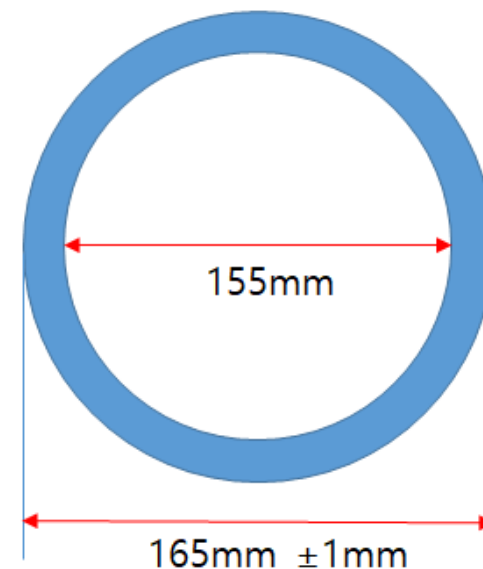

UN Regulation No. 122 (Heating system)

- Proposal for Supplement 7 to the Original Version of UN Regulation No. 122 (Heating systems)
 - Introduction of Radiation warmer
 - A device transmits heat to the human body in the way which radiates heat without direct contact with the human body and without an intermediate medium up to 180° C
 - Except for *Annex 5, Paragraph 2*
 - No such part or parts shall exceed a temperature of 70° C for uncoated metal or 80° C for other materials.

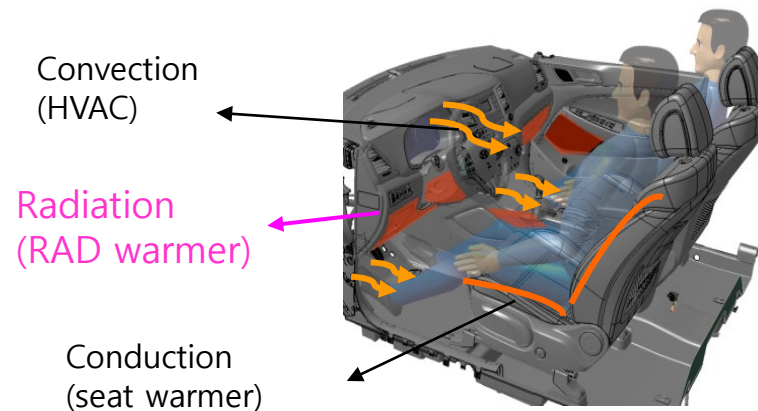
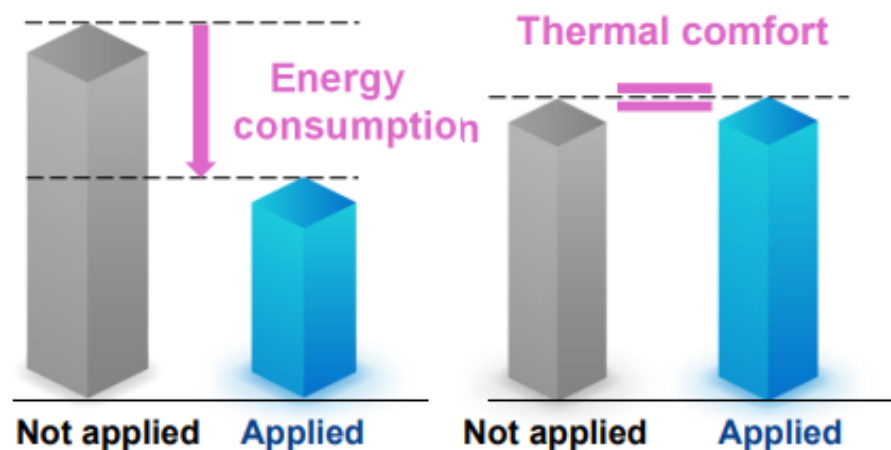

DPPS Informal Working Group

- Deployable Pedestrian Protection System (DPPS) - GTR No. 9
- Limited to the purpose of pedestrian Head Impact Time (HIT) and Wrap Around Distance (WAD) calculation
- Simulation tools are needed
- MR 1 – Addendum 5: Specifications for the Qualification of Human Body Models for Pedestrian HIT Determination for DPPS (DPPS tools)
- GTR9-03 amendment: HIT Determination and Assessment

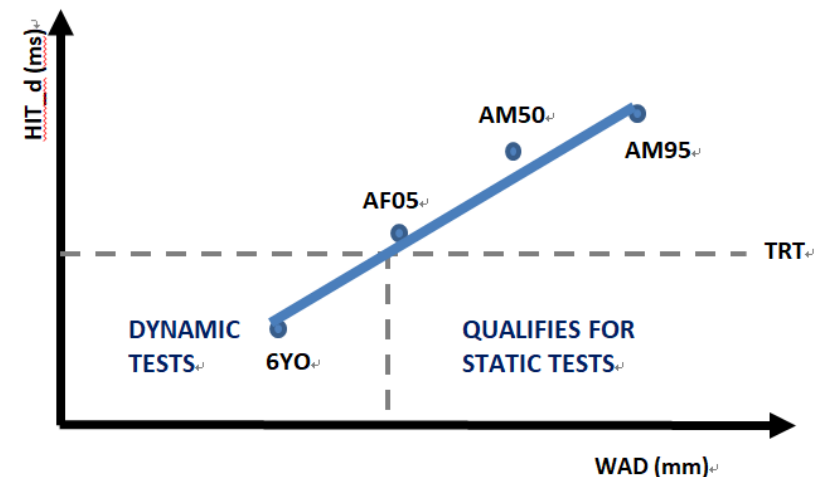
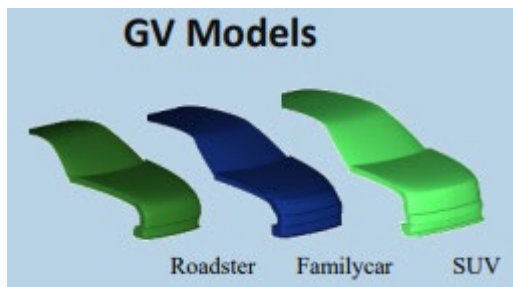

ACPE Informal Working Group

- Pedal Misapplication Accident Data in Korea
 - Time Period: Jan. 2022 ~ Sep. 2023 (21 months)
 - Pedal Misapplication suspected accident : 726 cases(Reported by the Manufacturers)
 - M1: 652 cases (89.8 %)
 - N1: 74 cases (10.2 %)
 - Propose to include N1



A-LCA Informal Working Group

- Automotive Life Cycle Assessment
- The clarification of methodologies for the assessment of life-cycle Greenhouse Gas (GHG) emissions of automotive
- 2023-2025: Meetings of IWG on A-LCA, with regular reporting to GRPE and WP.29
- SG1, SG2(Material and Material Recycling), SG3(Parts & Vehicle Production), SG4(Use phase), SG5(End of Life), SG6(Fuel & Energy Cycle), SG7(Drafting)
- Level Concept

LEVEL	WORK
Level 1 (Simplified LCA)	Focus on fuel cycle, and for vehicle cycle, generic raw material classifications and parts/vehicle productions according to the curb weight of the vehicle type, e.g. powertrain and fuel combination
Level 2 (Targeted LCA)	Focus on vehicle OEM's direct manageable scope and using globally standardized secondary DB for raw materials and major automobile parts reflecting vehicle OEM's own efforts
Level 3 (Extended LCA)	Expansion of supply chain evaluation and application of regional secondary DB or primary data which can reflect the efforts made in supply chain management
Level 4 (Full LCA)	Evaluation of CFP(carbon footprint) for the entire value chains based on primary data